

Standard Tables

Solutions to Triangles			
$A + B + C = 180^\circ$ $S = \frac{a + b + c}{2}$		Right 	Oblique 
Have	Want	Formulas for Right	Formulas for Oblique
abc	A	$\tan A = a/b$	$1/2A = \sqrt{(s-b)(s-c)/bc}$
	B	$90^\circ - A$ or $\cos B = a/c$	$\sin 1/2B = \sqrt{(s-a)(s-c)/a \times c}$
	C	90°	$\sin 1/2C = \sqrt{(s-a)(s-b)/a \times b}$
	Area	$a \times b/2$	$\sqrt{s \times (s-a)(s-b)(s-c)}$
aAC	B	$90^\circ - A$	$180^\circ - (A + C)$
	b	$a \cot A$	$a \sin B/\sin A$
	c	$a/\sin A$	$a \sin C/\sin A$
	Area	$(a^2 \cot A)/2$	$a^2 \sin B \sin C/2 \sin A$
acC	A	$\sin A = a/c$	$\sin A = a \sin C/c$
	B	$90^\circ - A$ or $\cos B = a/c$	$180^\circ - (A + C)$
	b	$\sqrt{c^2 - a^2}$	$c \sin B/\sin C$
	Area	$1/2a \sqrt{c^2 - a^2}$	$1/2 ac \sin B$
abC	A	$\tan A = a/b$	$\tan A = a \sin C/b - a \cos C$
	B	$90^\circ - A$ or $\tan B = b/a$	$180^\circ - (A + C)$
	c	$\sqrt{a^2 + b^2}$	$\sqrt{a^2 + b^2 - 2ab \cos C}$
	Area	$a \times b/2$	$1/2ab \sin C$

Rutland Tool and Supply Co., Inc.

Chord Length—Segments of Circles

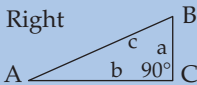
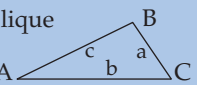

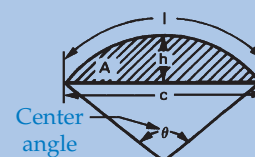
Length of arc (l =radians), height of segment (h), length of chord (c), and area of segment (A) for angles from 1 to 180 degrees and radius = 1. For other radii, multiply the values given for distance by the radius, and the values given for the area by r^2 , the square of the radius. The values in the table can be used for US Customary or metric units.



Center Angle θ , Degrees	l	h	c	Area of Segment A	Center Angle θ , Degrees	l	h	c	Area of Segment A	Center Angle θ , Degrees	l	h	c	Area of Segment A
1	0.01745	0.00004	0.01745	0.00000	61	1.065	0.1384	1.015	0.09502	121	2.112	0.5076	1.741	0.6273
2	0.03491	0.00015	0.03490	0.00000	62	1.082	0.1428	1.030	0.09958	122	2.129	0.5152	1.749	0.6406
3	0.05236	0.00034	0.05235	0.00001	63	1.100	0.1474	1.045	0.10428	123	2.147	0.5228	1.758	0.6540
4	0.06981	0.00061	0.06980	0.00003	64	1.117	0.1520	1.060	0.10911	124	2.164	0.5305	1.766	0.6676
5	0.08727	0.00095	0.08724	0.00006	65	1.134	0.1566	1.075	0.11408	125	2.182	0.5383	1.774	0.6813
6	0.10472	0.00137	0.10467	0.00010	66	1.152	0.1613	1.089	0.11919	126	2.199	0.5460	1.782	0.6950
7	0.12217	0.00187	0.12210	0.00015	67	1.169	0.1661	1.104	0.12443	127	2.217	0.5538	1.790	0.7090
8	0.13963	0.00244	0.13951	0.00023	68	1.187	0.1710	1.118	0.12982	128	2.234	0.5616	1.798	0.7230
9	0.15708	0.00308	0.15692	0.00032	69	1.204	0.1759	1.133	0.13535	129	2.251	0.5695	1.805	0.7372
10	0.17453	0.00381	0.17431	0.00044	70	1.222	0.1808	1.147	0.14102	130	2.269	0.5774	1.813	0.7514
11	0.19199	0.00460	0.19169	0.00059	71	1.239	0.1859	1.161	0.14683	131	2.286	0.5853	1.820	0.7658
12	0.20944	0.00548	0.20906	0.00076	72	1.257	0.1910	1.176	0.15279	132	2.304	0.5933	1.827	0.7803
13	0.22689	0.00643	0.22641	0.00097	73	1.274	0.1961	1.190	0.15889	133	2.321	0.6013	1.834	0.7950
14	0.24435	0.00745	0.24374	0.00121	74	1.292	0.2014	1.204	0.16514	134	2.339	0.6093	1.841	0.8097
15	0.26180	0.00856	0.26105	0.00149	75	1.309	0.2066	1.218	0.17154	135	2.356	0.6173	1.848	0.8245
16	0.27925	0.00973	0.27835	0.00181	76	1.326	0.2120	1.231	0.17808	136	2.374	0.6254	1.854	0.8395
17	0.29671	0.01098	0.29562	0.00217	77	1.344	0.2174	1.245	0.18477	137	2.391	0.6335	1.861	0.8546
18	0.31416	0.01231	0.31287	0.00257	78	1.361	0.2229	1.259	0.19160	138	2.409	0.6416	1.867	0.8697
19	0.33161	0.01371	0.33010	0.00302	79	1.379	0.2284	1.272	0.19859	139	2.426	0.6498	1.873	0.8850
20	0.34907	0.01519	0.34730	0.00352	80	1.396	0.2340	1.286	0.20573	140	2.443	0.6580	1.879	0.9003
21	0.36652	0.01675	0.36447	0.00408	81	1.414	0.2396	1.299	0.21301	141	2.461	0.6662	1.885	0.9158
22	0.38397	0.01837	0.38162	0.00468	82	1.431	0.2453	1.312	0.22045	142	2.478	0.6744	1.891	0.9314
23	0.40143	0.02008	0.39874	0.00535	83	1.449	0.2510	1.325	0.22804	143	2.496	0.6827	1.897	0.9470
24	0.41888	0.02185	0.41582	0.00607	84	1.466	0.2569	1.338	0.23578	144	2.513	0.6910	1.902	0.9627
25	0.43633	0.02370	0.43288	0.00686	85	1.484	0.2627	1.351	0.24367	145	2.531	0.6993	1.907	0.9786
26	0.45379	0.02563	0.44990	0.00771	86	1.501	0.2686	1.364	0.25171	146	2.548	0.7076	1.913	0.9945
27	0.47124	0.02763	0.46689	0.00862	87	1.518	0.2746	1.377	0.25990	147	2.566	0.7160	1.918	1.0105
28	0.48869	0.02970	0.48384	0.00961	88	1.536	0.2807	1.389	0.26825	148	2.583	0.7244	1.923	1.0266
29	0.50615	0.03185	0.50076	0.01067	89	1.553	0.2867	1.402	0.27675	149	2.601	0.7328	1.927	1.0428
30	0.52360	0.03407	0.51764	0.01180	90	1.571	0.2929	1.414	0.28540	150	2.618	0.7412	1.932	1.0590
31	0.54105	0.03637	0.53448	0.01301	91	1.588	0.2991	1.427	0.2942	151	2.635	0.7496	1.936	1.0753
32	0.55851	0.03874	0.55127	0.01429	92	1.606	0.3053	1.439	0.3032	152	2.653	0.7581	1.941	1.0917
33	0.57596	0.04118	0.56803	0.01566	93	1.623	0.3116	1.451	0.3123	153	2.670	0.7666	1.945	1.1082
34	0.59341	0.04370	0.58474	0.01711	94	1.641	0.3180	1.463	0.3215	154	2.688	0.7750	1.949	1.1247
35	0.61087	0.04628	0.60141	0.01864	95	1.658	0.3244	1.475	0.3309	155	2.705	0.7836	1.953	1.1413
36	0.62832	0.04894	0.61803	0.02027	96	1.676	0.3309	1.486	0.3405	156	2.723	0.7921	1.956	1.1580
37	0.64577	0.05168	0.63461	0.02198	97	1.693	0.3374	1.498	0.3502	157	2.740	0.8006	1.960	1.1747
38	0.66323	0.05448	0.65114	0.02378	98	1.710	0.3439	1.509	0.3601	158	2.758	0.8092	1.963	1.1915
39	0.68068	0.05736	0.66761	0.02568	99	1.728	0.3506	1.521	0.3701	159	2.775	0.8178	1.967	1.2084
40	0.69813	0.06031	0.68404	0.02767	100	1.745	0.3572	1.532	0.3803	160	2.793	0.8264	1.970	1.2253
41	0.71558	0.06333	0.70041	0.02976	101	1.763	0.3639	1.543	0.3906	161	2.810	0.8350	1.973	1.2422
42	0.73304	0.06642	0.71674	0.03195	102	1.780	0.3707	1.554	0.4010	162	2.827	0.8436	1.975	1.2592
43	0.75049	0.06958	0.73300	0.03425	103	1.798	0.3775	1.565	0.4117	163	2.845	0.8522	1.978	1.2763
44	0.76794	0.07282	0.74921	0.03664	104	1.815	0.3843	1.576	0.4224	164	2.862	0.8608	1.981	1.2934
45	0.78540	0.07612	0.76537	0.03915	105	1.833	0.3912	1.587	0.4333	165	2.880	0.8695	1.983	1.3105
46	0.803	0.0795	0.781	0.04176	106	1.850	0.3982	1.597	0.4444	166	2.897	0.8781	1.985	1.3277
47	0.820	0.0829	0.797	0.04448	107	1.868	0.4052	1.608	0.4556	167	2.915	0.8868	1.987	1.3449
48	0.838	0.0865	0.813	0.04731	108	1.885	0.4122	1.618	0.4669	168	2.932	0.8955	1.989	1.3621
49	0.855	0.0900	0.829	0.05025	109	1.902	0.4193	1.628	0.4784	169	2.950	0.9042	1.991	1.3794
50	0.873	0.0937	0.845	0.05331	110	1.920	0.4264	1.638	0.4901	170	2.967	0.9128	1.992	1.3967
51	0.890	0.0974	0.861	0.05649	111	1.937	0.4336	1.648	0.5019	171	2.985	0.9215	1.994	1.4140
52	0.908	0.1012	0.877	0.05978	112	1.955	0.4408	1.658	0.5138	172	3.002	0.9302	1.995	1.4314
53	0.925	0.1051	0.892	0.06319	113	1.972	0.4481	1.668	0.5259	173	3.019	0.9390	1.996	1.4488
54	0.942	0.1090	0.908	0.06673	114	1.990	0.4554	1.677	0.5381	174	3.037	0.9477	1.997	1.4662
55	0.960	0.1130	0.923	0.07039	115	2.007	0.4627	1.687	0.5504	175	3.054	0.9564	1.998	1.4836
56	0.977	0.1171	0.939	0.07417	116	2.025	0.4701	1.696	0.5629	176	3.072	0.9651	1.999	1.5010
57	0.995	0.1212	0.954	0.07808	117	2.042	0.4775	1.705	0.5755	177	3.089	0.9738	1.999	1.5184
58	1.012	0.1254	0.970	0.08212	118	2.059	0.4850	1.714	0.5883	178	3.107	0.9825	2.000	1.5359
59	1.030	0.1296	0.985	0.08629	119	2.077	0.4925	1.723	0.6012	179	3.124	0.9913	2.000	1.5533
60	1.047	0.1340	1.000	0.09059	120	2.094	0.5000	1.732	0.6142	180	3.142	1.0000	2.000	1.5708

Fraction, Decimal, and Metric Equivalents

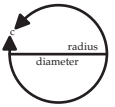
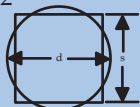
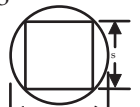
INCHES		MILLI-METERS	INCHES		MILLI-METERS	
FRACTIONS	DECIMALS		FRACTIONS	DECIMALS		
	.00394	.1		$\frac{15}{32}$.46875	11.9063
	.00787	.2		$\frac{31}{64}$.47244	12.00
	.01181	.3		$\frac{1}{2}$.484375	12.3031
	$\frac{1}{64}$.3969		$\frac{33}{64}$.5000	12.70
	.01575	.4		$\frac{17}{32}$.51181	13.00
	.01969	.5		$\frac{35}{64}$.515625	13.0969
	.02362	.6		$\frac{9}{16}$.53125	13.4938
	.02756	.7		$\frac{37}{64}$.546875	13.8907
	$\frac{1}{32}$.7938		$\frac{19}{32}$.55118	14.00
	.03125	.8		$\frac{5}{8}$.5625	14.2875
	.0315	.9		$\frac{39}{64}$.578125	14.6844
	.03543	1.00		$\frac{41}{64}$.59055	15.00
	.03937			$\frac{21}{32}$.59375	15.0813
	$\frac{3}{64}$.046875		$\frac{43}{64}$.609375	15.4782
	$\frac{5}{64}$.0625		$\frac{45}{64}$.625	15.875
	$\frac{1}{16}$.078125		$\frac{11}{16}$.62992	16.00
	$\frac{3}{32}$.09375		$\frac{23}{32}$.640625	16.2719
	$\frac{7}{64}$.109375		$\frac{47}{64}$.65625	16.6688
	$\frac{1}{8}$.11811		$\frac{49}{64}$.66929	17.00
	.125	3.175		$\frac{51}{64}$.671875	17.0657
	$\frac{9}{64}$.140625		$\frac{3}{4}$.6875	17.4625
	$\frac{5}{32}$.15625		$\frac{25}{32}$.703125	17.8594
	$\frac{11}{64}$.15748		$\frac{13}{16}$.70866	18.00
	$\frac{3}{16}$.171875		$\frac{27}{32}$.71875	18.2563
	$\frac{13}{64}$.1875		$\frac{47}{64}$.734375	18.6532
	$\frac{7}{32}$.19685		$\frac{53}{64}$.74803	19.00
	$\frac{15}{64}$.203125		$\frac{55}{64}$.7500	19.05
	$\frac{1}{4}$.21875		$\frac{57}{64}$.75625	19.4469
	.234375	5.5563		$\frac{7}{8}$.78125	19.8438
	.23622	6.00		$\frac{29}{32}$.7874	20.00
	.2500	6.35		$\frac{59}{64}$.796875	20.2407
	$\frac{17}{64}$.265625		$\frac{15}{16}$.8125	20.6375
	.27559	7.00		$\frac{61}{64}$.82677	21.00
	$\frac{9}{32}$.28125		$\frac{27}{32}$.828125	21.0344
	$\frac{19}{64}$.296875		$\frac{53}{64}$.84375	21.4313
	$\frac{5}{16}$.3125		$\frac{55}{64}$.859375	21.8282
	.31496	8.00		$\frac{57}{64}$.86614	22.00
	$\frac{21}{64}$.328125		$\frac{7}{8}$.875	22.225
	$\frac{11}{32}$.34375		$\frac{59}{64}$.890625	22.6219
	.35433	9.00		$\frac{29}{32}$.90551	23.00
	$\frac{23}{64}$.359375		$\frac{15}{16}$.90625	23.0188
	$\frac{3}{8}$.375		$\frac{61}{64}$.921875	23.4157
	$\frac{25}{64}$.390625		$\frac{31}{32}$.9375	23.8125
	.3937	10.00		$\frac{63}{64}$.94488	24.00
	$\frac{13}{32}$.40625		$\frac{1}{1}$.94875	24.2094
	$\frac{27}{64}$.421875			.96875	24.6063
	.43307	11.00			.98425	25.00
	$\frac{7}{16}$.4375			.984375	25.0032
	$\frac{29}{64}$.453125			1.0000	25.4000

Area Equivalents	
1	
2	
3	
4	
1	area = radius ² × 3.1416 or diameter ² × .7854
1	circumference = diameter × 3.1416 or diameter ÷ .3183
2	when the area of a circle & square are equal, D = S × 1.128
2	when the area of a circle & square are equal, S = D × .8862
3	side of inscribed square = diameter × .7071
3	diameter of circumscribing circle = S × 1.4142
4	surface area of a sphere = diameter × circumference
4	volume of a sphere = diameter ³ × .5236

Length Conversions		
multiply	by	to obtain
Inches	25.4	Millimeters
Feet	304.8	Millimeters
Inches	2.54	Centimeters
Feet	30.48	Centimeters
Millimeters	.03937008	Inches
Centimeters	.3937008	Inches
Meters	39.37008	Inches
Millimeters	.003280840	Feet
Centimeters	.03280840	Feet
Inches	.0254	Meters

Equivalents	
Fahrenheit and Celsius	
°F = (1.8 × °C) + 32	
°C = (°F - 32) ÷ 1.8	
Weight	
1 gram = .03527 oz (av.)	
1 oz = 28.35 grams	
1 kilogram = 2.2046 pounds	
1 pound = .4536 kilograms	
1 metric ton = 2,204.6 pounds	
1 ton (2000 lbs in U.S.) = 907.2 kg	
Volume	
1 U.S. quart = 0.946 liters	
1 U.S. gallon = 3.785 liters	
1 liter = 1.0567 U.S. quarts	
1 liter = .264 U.S. gallons	

Square Area Conversions		
multiply	by	to obtain
Millimeters	.00001076391	Feet
Millimeters	.001550003	Inches
Centimeters	.1550003	Inches
Centimeters	.001076391	Feet
Inches	645.16	Millimeters
Inches	6.4516	Centimeters
Inches	.00064516	Meters
Feet	.09290304	Meters
Feet	929.0304	Centimeters
Feet	92,903.04	Millimeters

Rutland Tool and Supply Co., Inc.