

Exercise 17-5

1. Continue from Exercise 17-4 or start AutoCAD.
2. Start a new drawing from scratch or use a decimal-unit template of your choice. Save the drawing as EX17-5.
3. Set up appropriate layers, including a layer for dimensions.

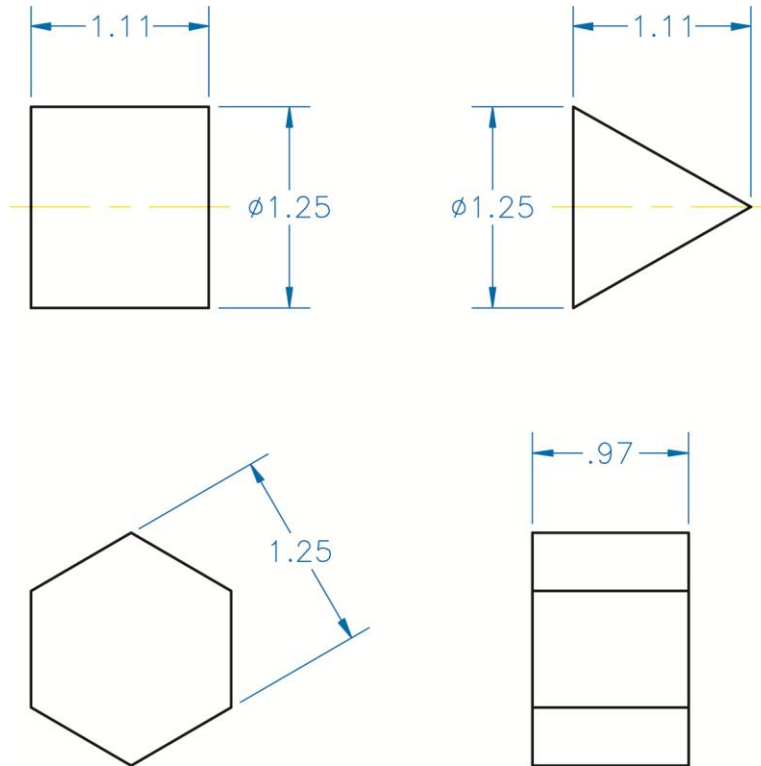

4. Draw the objects shown.
5. Create an appropriate dimension style and dimension the objects as shown using the **DIM**, **DIMLINEAR**, and **DIMALIGNED** commands.
6. Resave and close the file.
7. Keep AutoCAD open for the next exercise, or exit AutoCAD if necessary.