

Exercise 26-7

1. Continue from Exercise 26-6 or start AutoCAD.
2. Start a new drawing from scratch or use a decimal-unit template of your choice. Save the drawing as EX26-7.
3. Draw the gate valve shown in the figure. Do not include dimensions.

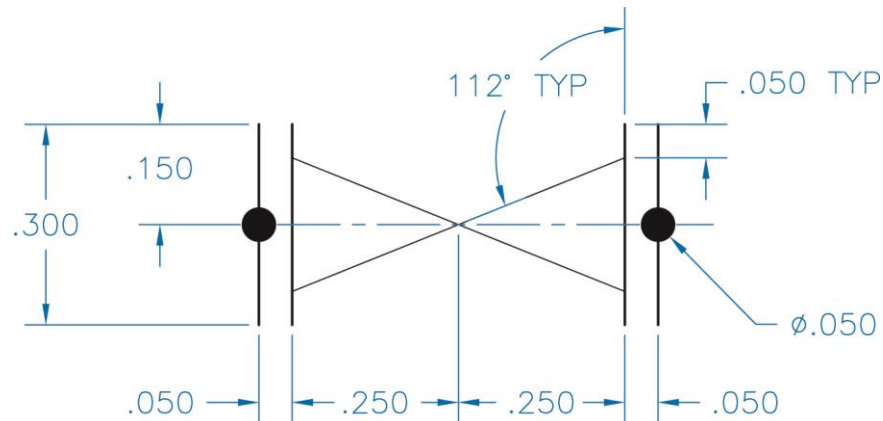

4. Create a block named VALVE and open it in the **Block Editor**.
5. Insert an alignment parameter. Pick the base point where the two diagonal lines cross. Set the alignment type to be perpendicular. Then pick the center of either of the circles to specify the alignment direction.
6. Enter the **Test Block Window**.
7. Draw a line at an angle other than horizontal. Select the block to display grips. Select the alignment parameter grip, move the block near the line until it aligns with the line, and pick.
8. Close the **Test Block Window** and make changes to the block if the valve did not align as expected.
9. Retest the block if you made changes.
10. Save the block and exit the **Block Editor**.

11. Draw the single-line piping diagram shown and insert the VALVE block.

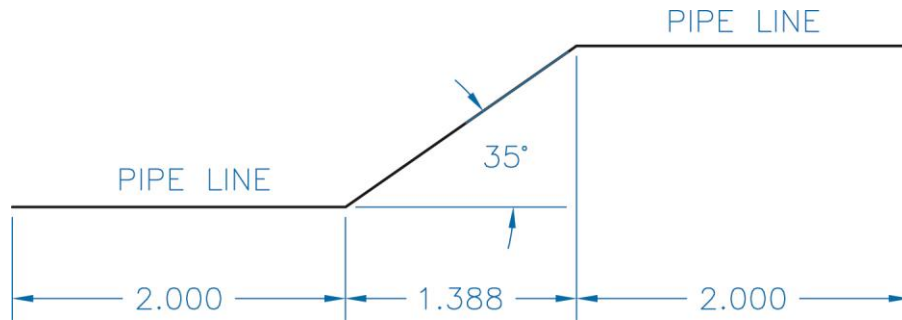

12. Select the block to display grips and select the alignment parameter grip.
13. Move the block near the diagonal pipeline segment until it aligns with the line and pick. Tip: Since the base point is in the middle of the valve, you can use the **Midpoint** object snap to center the block on the pipe segment.
14. Resave and close the file.
15. Keep AutoCAD open for the next exercise, or exit AutoCAD if necessary.