

## Exercise 14-3

1. Open the drawing EX14\_03.dwg available on the companion website.
2. Switch to the A-Size layout.
3. Referring to the illustration below, create the top view as the base view. Use a scale of 1:4.
4. Create a half section view as the front view. Use object snaps and tracking as needed to draw the section line.
5. Create the isometric view as a projected isometric section view from the front view. The isometric view should be a shaded view as shown.

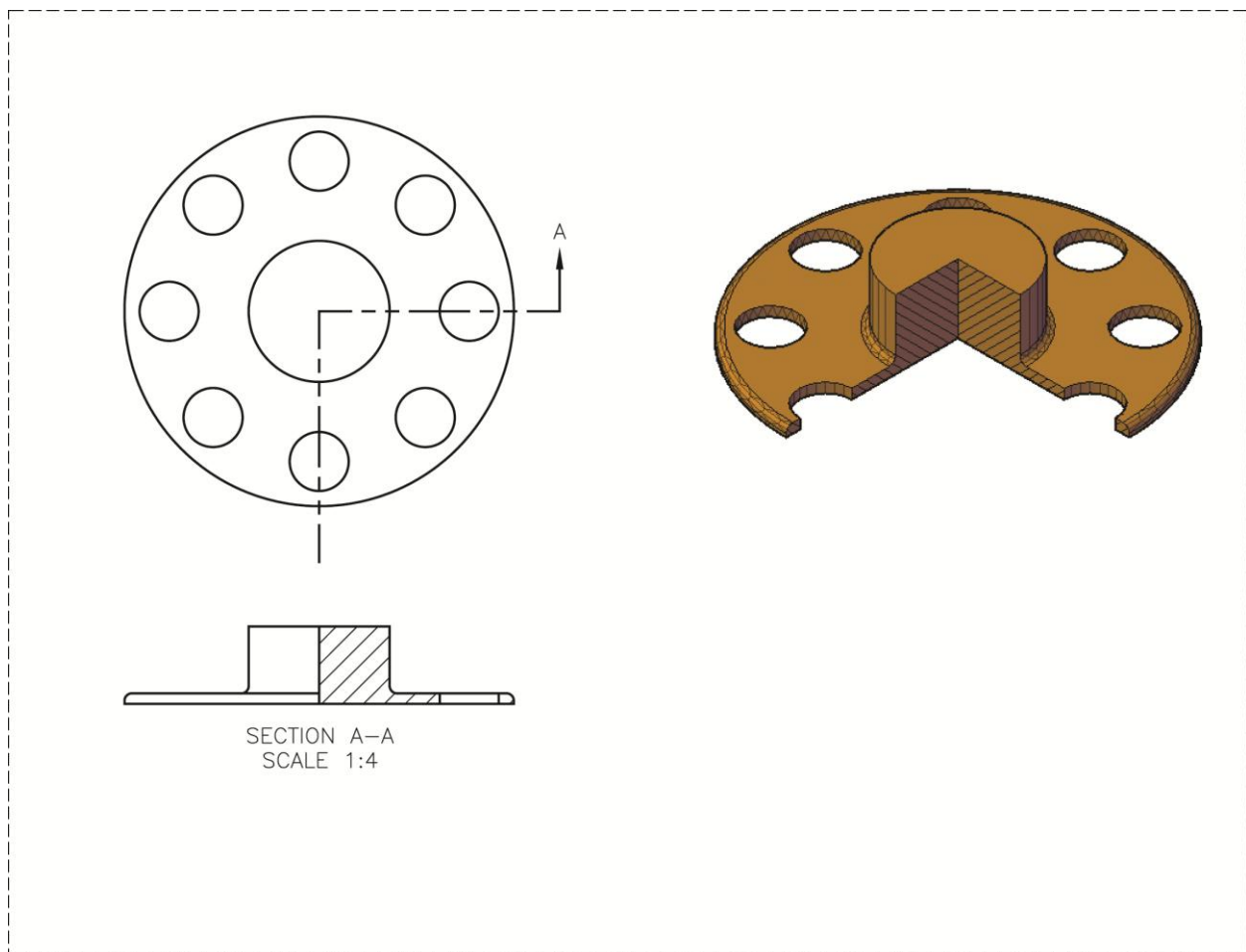

6. Save the drawing as EX14-3.