

Exercise 26-4

1. Continue from Exercise 26-3 or start AutoCAD.
2. Start a new drawing from scratch or use a decimal-unit template of your choice. Save the drawing as EX26-4.
3. Draw the objects shown in the figure.

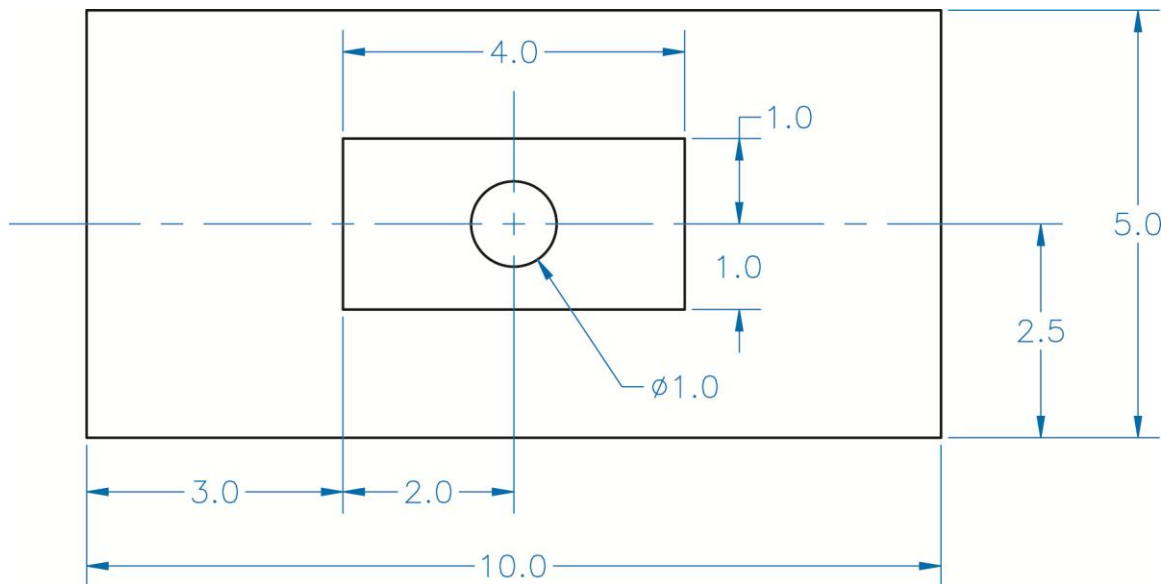

4. Create a block named SHUTTER from the two rectangles and circle. Open the block in the **Block Editor**.
5. Insert a linear parameter along the top of the inner rectangle. Pick the endpoints of the rectangle when inserting the parameter.
6. Assign a scale action to the linear parameter. Select the inner rectangle, circle, and linear parameter as the objects to which the action applies.
7. Use the **Independent** option to set the center of the circle as the base location.
8. Enter the **Test Block Window**.
9. Select the block to display grips. Move the parameter grip around to see the scale change dynamically.
10. Close the **Test Block Window** and make changes to the block if the objects did not scale as expected.
11. Retest the block if you made changes.
12. Save the block and exit the **Block Editor**.

13. Insert the block into the current drawing.
14. Enable dynamic input if it is not already enabled. Select the block to display grips. Select either of the linear parameter grips and type 6 in the distance field.
15. Resave and close the file.
16. Keep AutoCAD open for the next exercise, or exit AutoCAD if necessary.