

assign to dimension styles. You can create isometric text styles and dimension styles for each isometric plane. However, you may find it easier to use standard text and dimension styles and edit each dimension as necessary to create isometric dimensions.

Add dimensions using the **DIM** or **DIMALIGNED** command. See **Figure 20A-2A**. You can use the **DIM**, **DIMALIGNED**, or **DIMLINEAR** command to dimension vertically aligned points, but you must use the **DIM** or **DIMALIGNED** command for all other applications. Then use the **Oblique** option of the **DIMEDIT** command to align the extension lines with the isometric plane. Pick the dimension to edit and specify the isometric angle. Enter a specific value, such as 30 or 210, or pick two points. See **Figure 20A-2B**.

Rotate the dimension text to align with the isometric plane. See **Figure 20A-2C**. Use the **Rotate** option of the **DIMEDIT** command or the **Angle** option of the **DIMTEDIT** command. Finally, edit the dimension text to specify an obliquing angle according to the isometric plane. See **Figure 20A-2D**. If you did not prepare separate isometric text and dimension styles, use the **TEXTEDIT** command to modify the obliquing angle using the **Oblique Angle** text box in the **Formatting** panel of the **Text Editor** ribbon tab.

Figure 20A-2.

The steps required to create isometric-looking dimensions using dimension commands. A—Use the **DIM** or **DIMALIGNED** command to dimension features. B—Use the **Oblique** option of the **DIMEDIT** command to edit the obliquing angle of extension lines. Be sure to specify the correct isometric angle. C—Use the **Rotate** option of the **DIMEDIT** command or the **Angle** option of the **DIMTEDIT** command to rotate the dimension text. D—Use the **TEXTEDIT** command to edit the obliquing angle of dimension text.

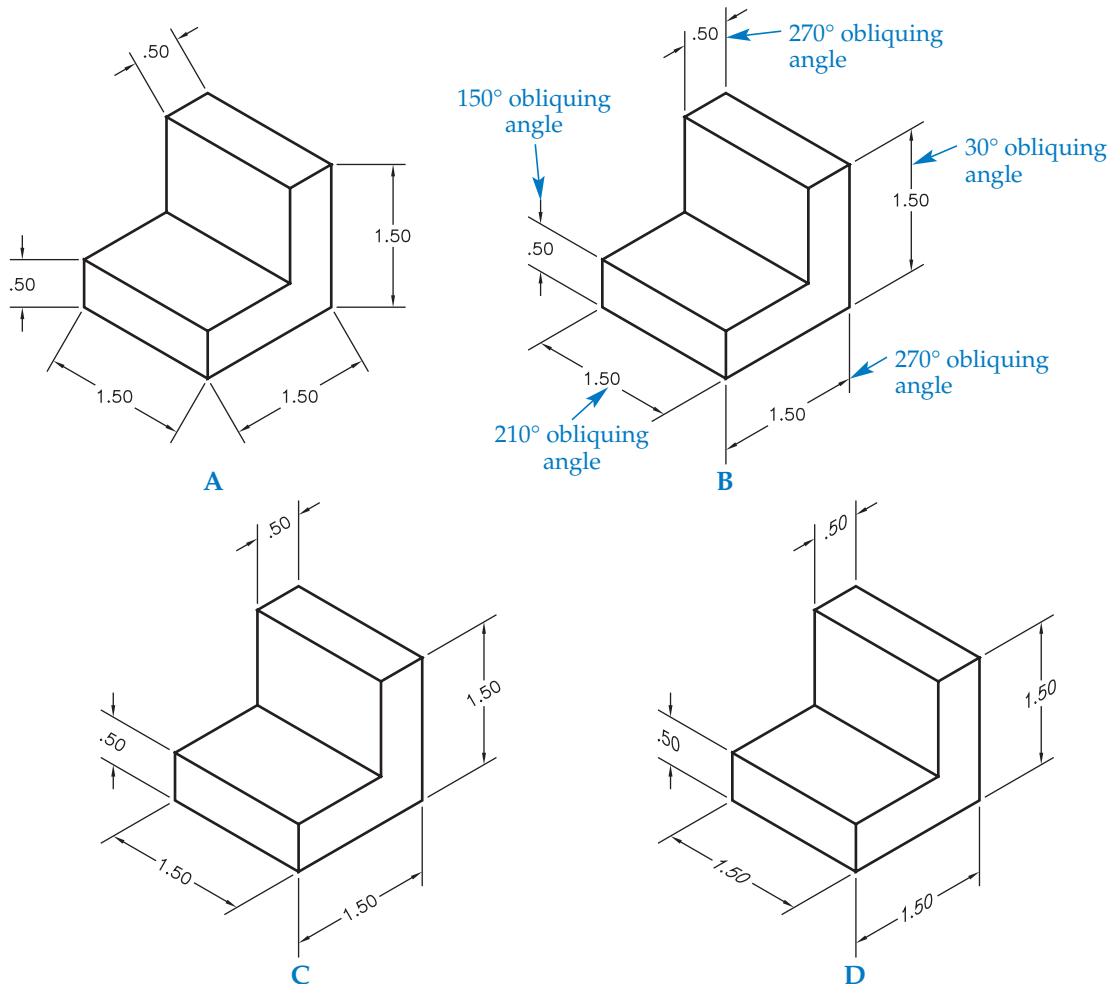

NOTE

If you plan to add isometric arrowheads as separate objects, you can assign the **None** option to each drop-down list in the **Arrowheads** area in the **Symbols and Arrows** tab of the **New** (or **Modify**) **Dimension Style** dialog box. However, without arrowheads, the fit between close extension lines will not respond correctly. The dimension value and short dimension lines appear inside extension lines, without room for arrowheads.

Isometric Arrowheads

True isometric dimensions require isometric arrowheads. See **Figure 20A-3**. To create an isometric arrowhead, use geometric construction and a command such as **PLINE** to draw the outline of the arrowhead. Use the same dimensions as those for a standard arrowhead, using a 3:1 ratio and a .125" (3 mm) length. The wide portion of the arrowhead is parallel to the extension line. See **Figure 20A-4A**.

Use the **HATCH** or **SOLID** command to create filled arrowheads. Chapter 23 explains using the **HATCH** command, which is often the best method to apply a solid fill. To create filled arrowheads using the **SOLID** command, access the command and pick three points, or corners, in a clockwise or counterclockwise order. Then press [Enter] twice to create the fill and exit the command. See **Figure 20A-4B**.

Type
SOLID

SOLID

Figure 20A-3.
An example of a drawing with true isometric dimension arrowheads. If you look closely, you can see that the wide portion of the arrowhead is parallel to the extension line.

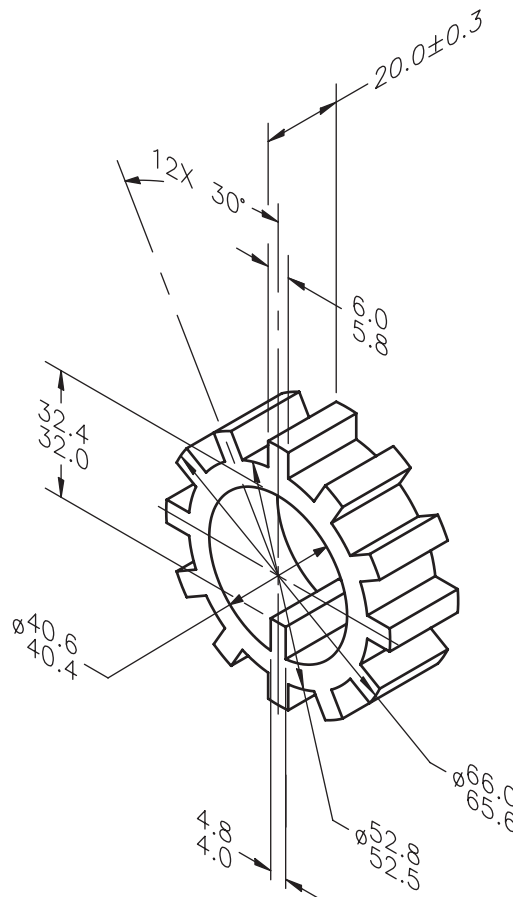

Title: Locking Collar
Material: SAE 1080
Metric

Figure 20A-4.

A—Constructing the outline of isometric arrowheads. The wide portion of the arrowhead and the arrowhead length are the same as those of nonisometric arrowheads, but the wide portion of the arrowhead is parallel to the extension line. B—Arrowheads filled using the **HATCH** command.

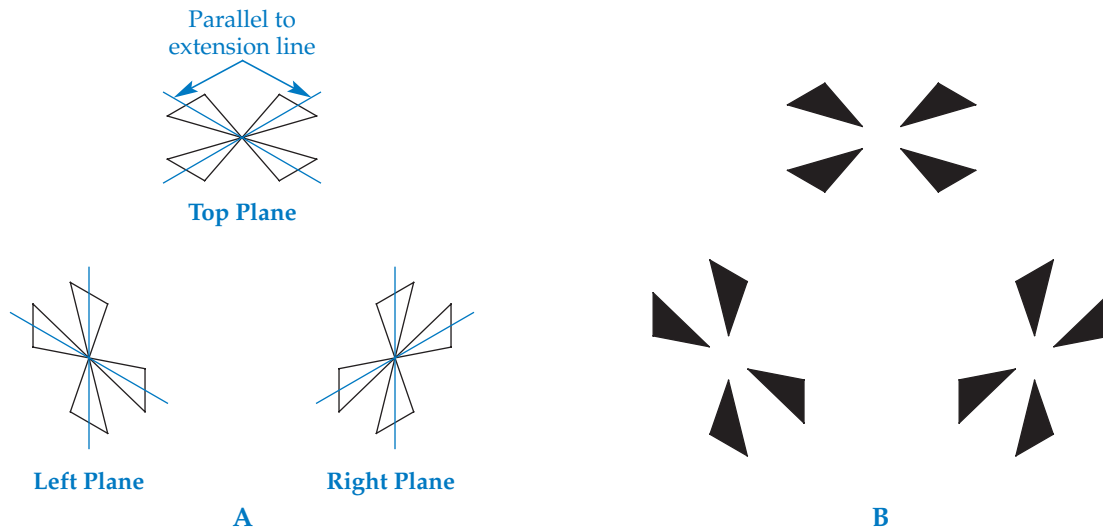

NOTE

Save each arrowhead as a block for repeated use, and to group the outline with the fill. Blocks are described in Chapter 24.

Activity 20A-1

1. Start a new drawing from scratch or use a template of your choice. Save the drawing as ACT20A-1.
2. Draw the part shown in **Figure 20A-2**.
3. Use an appropriate text and dimension style to dimension the part as shown in **Figure 20A-2D**.
4. Resave and close the file.